

HOTEL-TYPE SWITCH, ILLUMINATED

type: ..WH../..

Technical data

Working voltage	230V~/50Hz
Rated current	10(2)A
Insulation distance	μ (micro-gap)
Protection grade	IP20

Applications

Hotel switch..WH../.. is dedicated for:

- Operating of supplying relay (contactor),
- direct operating of the presence signalling circuits.

Connection to the electric system

..WH1/..

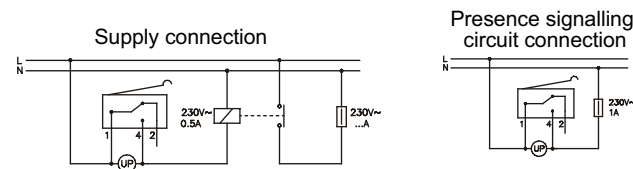

...A (load) - depending on the relay (contactor) used
UP – illumination

..WH2/..

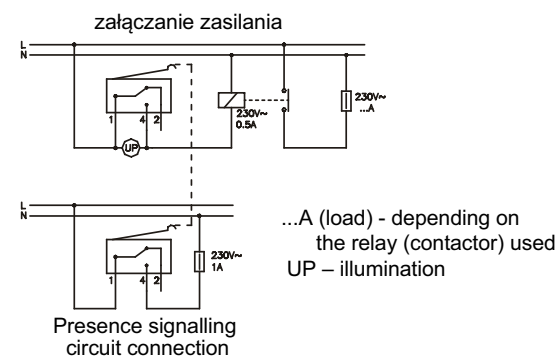

...A (load) - depending on the relay (contactor) used
UP – illumination

ROTARY PUSH DIMMER

DS9T.01/..,
MS9T.01/.., MS9T/..,
BMS9T.01/..

Application

The dimmer is designed for switching ON/OFF the light and the light intensity adjustment in apartments, offices, shops etc. In order to switch ON/OFF the light it is necessary to push the handwheel. The light intensity is being adjusted by rotating the handwheel. In order to increase the light intensity it is necessary to turn the handwheel right (clockwise).

The dimmer may be applied in the two-way and intermediate installations.

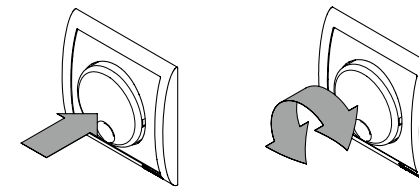

Light sources

	230 V incandescent lamps	20 ÷ 500 W
	230 V halogen lamps	20 ÷ 500 W
	12 V halogen lamps connected through a core-type transformer 230/12Vac	20 ÷ 500 W
	connected through an electronic transformer 230/12Vac	20 ÷ 500 W
	Energy-save lighting	
	Fluorescent lamps	
	LED lamps	

WARNING: The dimmer is not designed for interoperation with the core-type column transformers, fans and other devices fitted with an electric motor. Failure to observe this warning may cause the dimmer failure.

Short circuit protection

The dimmer is fitted with the short circuit protection that switches the load (lighting) OFF when the load current exceeds 20 A. After the short circuit cause removal it is possible to switch the dimmer ON again.

In case of burnout of 230 V light bulb the load current may reach the limit value what will cause the the lighting switching OFF and prevent the bulb from complete burnout. **When the automatic switching OFF repeats over and over again it is necessary to check the bulb stale and replace it if needed.**

Connecting the dimmer to the electrical system

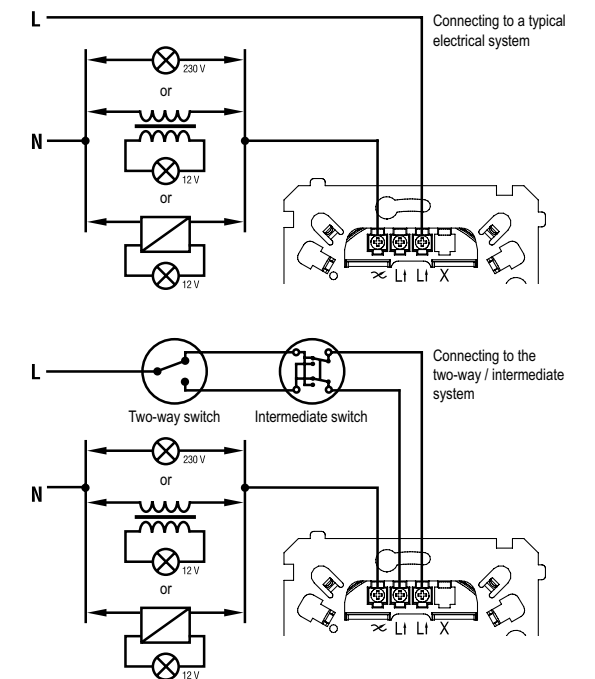

Technical data

Operating voltage	230 V/50 Hz
Load range	20 ÷ 500 W
Type of load	incandescent and 230 V halogen lamps, 12 V halogen lamps supplied via core-type or electronic transformers 230/12 V according to PN-EN-55015
Interference level	IP20
Degree of protection	continuous
Operating mode	smooth
Adjustment mode	100g
Weight	

CONTROLLER 1 ÷ 10V DS9V.01/.. BMS9V.01/..

Application

The 1 ÷ 10V Controller is designed to switch-off/switch-on and/or to control light intensity of:

- fluorescent lamps, connected through dimmable electronic ballasts,
- 12V halogen lamps, connected through electronic dimmable transformers,
- LED lighting, connected through dimmable feeders.

Switching off/on is effected by pressing the control knob, and adjustment by turning the control knob. Brighter light is achieved by turning the control knob clockwise.

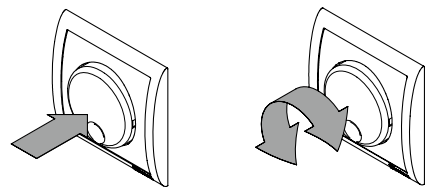

Adjustment is effected through the 1 ÷ 10V line connected to control inputs of the above mentioned appliances. One Controller can be connected to few dimmable appliances having 1 ÷ 10V inputs.

Technical data

Control voltage	0.7 ÷ 11V
Control output load current	50mA
Switch contact load current	6A/230V~
Interference level	conforms to PN-EN-55015
IP Protection	IP20
Type of operation	continuous service
Type of control	smooth
Weight	75g

Diagram of controller connection to the electric system

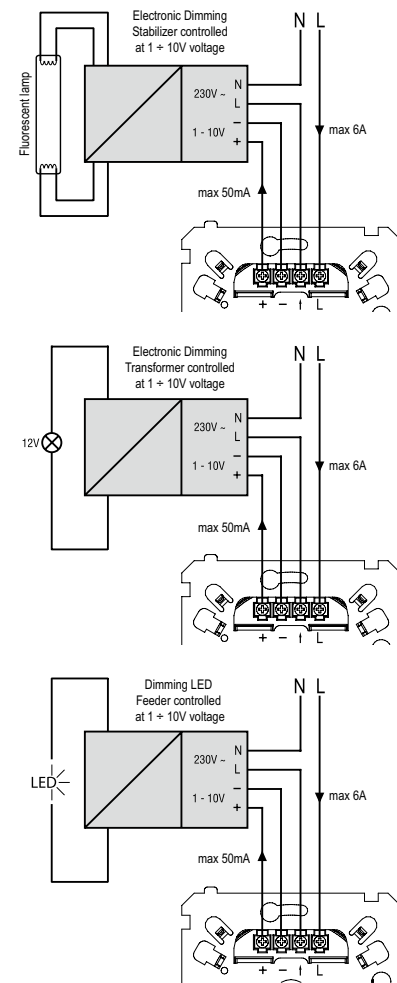

DOUBLE-POLE ROTARY DIMMER FOR LED LIGHTING DS9L2.01/..

Application

The Double-Pole Rotary Dimmer for LED lighting is designed to switch-off/switch-on and/or to control light intensity of the dimmable LED lighting sources supplied at 230V~ (e.g. Philips MASTER). The 3- or 4-wire connection system (including a neutral N wire) provides a wide range of brightness control, smoothly operated across its full range, and the double-pole switch incorporated into the Dimmer allows for using the Dimmer in installations requiring a double-pole type of the illumination lamp switch-off system. Switching off/on and/or adjustment operations are effected by turning the control knob. Brighter light is achieved by turning the control knob clockwise.

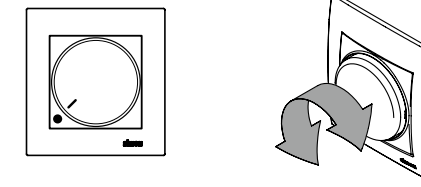

Switching off is effected by turning the knob anticlockwise home (into position marked •).

Light sources

	230Vac incandescent lamps	5 ÷ 215W
	230Vac halogen lamps	5 ÷ 215W
	dimmable LED lighting	5 ÷ 215W
	energy-saving lamps	
	fluorescent lamps	

WARNING: The dimmer is not designed for interoperation with the core type toroidal or column transformers, fans and other devices fitted with an electric motor. Failure to observe this warning may cause the dimmer failure.

Short-circuit protection

The Dimmer is equipped with the short-circuit protection system switching off the load circuit (i.e. switching off the lighting) when current intensity exceeds 20A. Upon a short-circuit failure is repaired, the Dimmer may be switched on again. In a while a 230V bulb is just to be burned out, the current can reach the protection limit value resulting in a self-acting switch-off of a bulb, preventing the bulb to be totally burned-out. **When a self-acting switch-off repeats frequently, check condition of the bulb, and replace it if needed.**

Diagram of the dimmer connection to the electric system

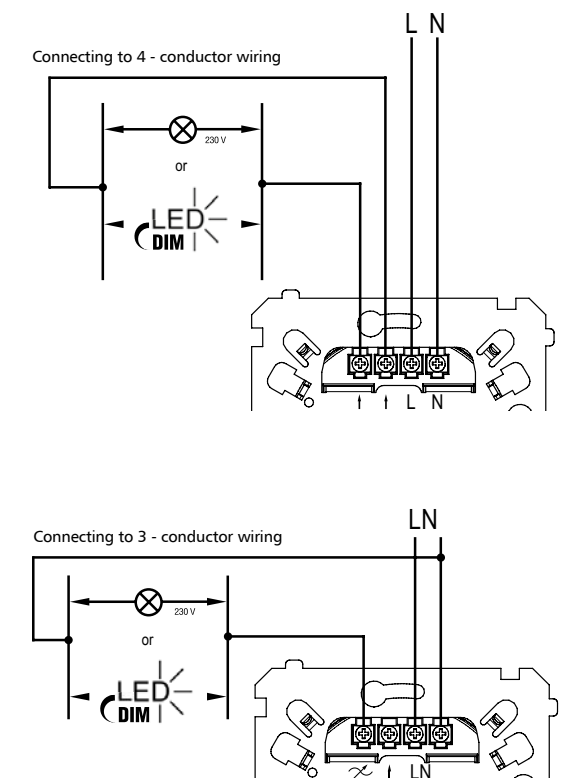

Technical data

Operating voltage	230 V/50 Hz
Load power	5 ÷ 215 W
Type of load	incandescent/halogen load 230V, dimmable LED lighting
Interference level	conforms to PN-EN-55015
IP Protection	IP20
Type of operation	continuous service
Type of control	smooth
Weight	100g

REMOTE OPERATED LIGHT-DIMMER DS13T.01/.. MS13T.01/.., MS13T/..

Application

The Light-Dimmer is designed to switch the light on/off and/or to control light intensity in habitable rooms and/or other compartments, as offices, shops, etc. Light switching on/off and/or control operations are effected by pressing the Dimmer push-button, or remotely, using any TV remote controller.

The Dimmer can also be used in any two-way or intermediate type electric system.

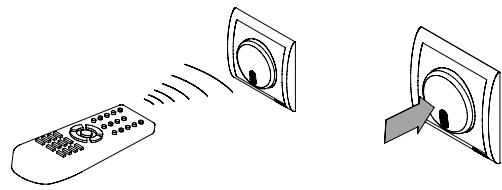

Light sources



230 V incandescent lamps 20 ÷ 500 W



230 V halogen lamps 20 ÷ 500 W
12 V halogen lamps connected through a core-type toroidal transformer 230V/12V 20 ÷ 500 W
connected through an electronic transformer 230V/12V 20 ÷ 500 W



energy-saving lighting

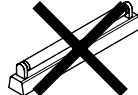

fluorescent lamps



LED lighting



WARNING: The dimmer is not designed for inter-operation with the core-type column transformers, fans and other devices fitted with an electric motor. Failure to observe this warning may cause the dimmer failure.

Operation

The Dimmer can be directly operated by:

- pressing a push-button of the Dimmer,
- pressing an additional LIGHT push-button, connected to the Dimmer;

or operated remotely by:

- any TV remote controller.

Direct Operation:

A short press of the Dimmer push-button, or the additional switch, effects switching the light on/off, whilst a long press causes adjustment of light brightness till the push-button is released. Adjustment is performed upward/downward, and when a limit position (maximal or minimal) is reached the adjustment direction is reversed.

Operation, using a TV Remote Controller, can be performed in two ways:

1. using any button of the Controller, pressing it twice with an interval not longer than 2 seconds:

- The first press on the TV controller push-button brings the Dimmer to stand-by, expecting for a next signal from the controller.
- The Dimmer stand-by is signalled by the LED switch-off lasting ca 2 seconds since the push-button is released, and during that time a second press of the controller push-button should be effected.

If the second signal from the controller does not appear, the LED shines again signalling the stand-by mode is over.

- The second press on the TV controller push-button operates in the same way as a direct operation of the Dimmer push-button. Upon release of the push-button the LED shines again.

2. using programmed push-button of the TV remote controller, pressing it once. The press of the TV controller push-button operates in the same way as direct operation of the Dimmer push-button.

The LED, shining continuously, signals that there are no operations of the TV controller.

Programming of the TV controller push-button

Programming:

1. press quickly the Dimmer push-button 6 times;
2. setting of the programming mode is signalled by the light switched off and the LED flickering in a cycle: light on for 1.5s / off for 0.5s;
3. press and hold down the selected push-button on the TV controller (a push-button that is usually not used to operate TV is the best); upon the signal from the TV controller is stored in, the lamp starts to brighten, as while brightness adjustment, and the LED stops to flicker; the Dimmer leaves the programming mode;
4. release the push-button on the TV controller, check switching the light on/off by short pressing the push-button, press another push-button on the TV controller to check whether the Dimmer reacts only to the programmed push-button.

Programming of a push-button can be performed many times, repeating the above operations. Any decay of voltage does not effect a loss of the stored signal from the TV controller.

In case, the signal from the TV controller is not recognised, a trial to program any other TV controller should be repeated. Until the signal from the TV controller is stored, the Dimmer is in the programming mode; however, after 5 minutes of inactivity the Dimmer leaves the programming mode automatically, or it leaves the mode by a manual switching off.

Termination Of The Programming:

1. No Changes In Programming
Press shortly the push-button on the Dimmer, the LED stops to flicker, the Dimmer remains in a mode as prior to programming, i.e. the stored signal from the TV controller is active still or the Dimmer is controlled upon double pressing of any push-button;
2. Deleting The Storage
Press and hold down the Dimmer push-button for 3s, when the LED stops to flicker release the push-button, the Dimmer resets the stored push-button, and upon double pressing on any push-button of the TV controller, it enters the remote operation mode.

Short-circuit protection

The Dimmer is furnished with the short-circuit protection system switching off the load circuit (switching off the light) upon exceeding 20A current. When a short-circuit is repaired, the Dimmer may be switched on again. When a bulb 230V is close to be burnt out, current can also achieve a protection limit and that is manifested by automatic switching the light off, preventing the bulb to be burnt out.

When automatic switching the light off is frequent, the bulb should be checked and replaced, if needed.

Overload protection

The Dimmer has an overload protection reducing light brightness after few seconds, according to exceeding the power rating of the Dimmer.

In case the power rating is exceeded above 50% the light is completely switched off. Upon the protection system has operated, the Dimmer shifts to the off-state.

The LED signals the off cause:

- single flash: short-circuit,
- double flash: >50% overload.

Pressing the Dimmer push-button effects the automatic switch-off mode of the Dimmer is deleted, and the Dimmer is shifted to standard operation.

Diagram of the dimmer connection to the electric system

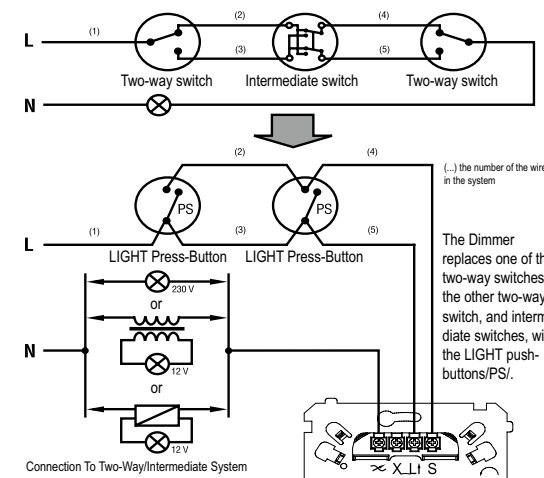
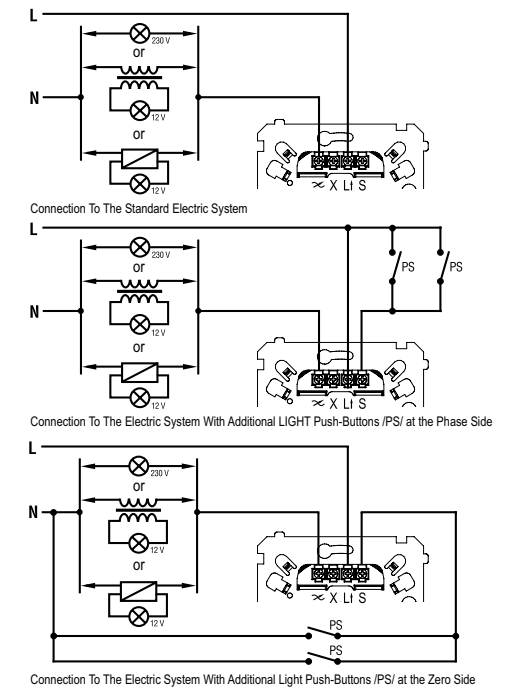



REMOTE CONTROL RELAY SWITCH DWP10P.01/..

Application

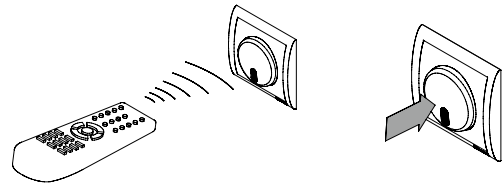
The Switch is designed to switch the light on/off in habitable rooms and/or other compartments, as offices, shops, etc. The light switching on/off operations are effected by pressing the Switch push-button, or pressing a button on any RTV pilot (remote controller).

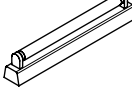
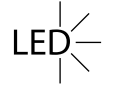
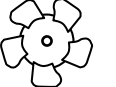

Permissible types of load

	230Vac incandescent lamps	max. 2000W
	230Vac halogen lamps 12Vac halogen lamps connected through a coretype transformer 230/12Vac connected through an electronic transformer	max. 2000W max 1000 W max 2000 W
	energy-saving lamps	max 2000 W
	fluorescent lamps without compensation and with the series compensation circuit with the parallel compensation circuit and connected by duo-circuit	max 1000 W max 2000 W
	LED lamps	max 2000 W
	fans	max 4500 W

Operation

The methods the Switch can be operated:

- REMOTE OPERATION:** using any RTV pilot/remote controller (2 methods, as described beneath),
- DIRECT OPERATION:** a short press of the Switch's button effects switching the light on/off.

REMOTE OPERATION (operating any RTV pilot) – 2 METHODS:

- Using ANY BUTTON on the RTV pilot (assumed configuration) - double depression:**

- First press is long, ca 1sec (till the LED in the switch button is off),
- Second press is short, switching the light on/off.

(The second press must be done in 2 sec after the first press- if not, the stand-by position is over and the LED shines again).

- Using PREPROGRAMMED BUTTON** on the RTV pilot by a **single pressing** the dedicated (assigned) button on the pilot, switching the light on/off.

The description how to shift from a double press (assumed) operation mode to a single press operation (assigning the button on the RTV pilot) is shown beneath.

Assigning the RTV pilot button to switch the lighting on/off

Programming:

- press quickly the Switch's button 6 times; setting the programming mode is signalled by the light is off and the LED is flickering in a cycle: light is on 1.5s / off 0.5s;
- press and hold down the selected button on the pilot (the best is a one that is not used in operation of the RTV equipment); upon the signal from the pilot is already stored the light is on and the LED stops to flicker, the programming operation is completed;
- release the button on the pilot, check switching the light on/off operation by short pressing the assigned button on the pilot, press also few other buttons on the pilot to confirm the switch reacts only to the programmed button.

Programming of the button can be performed many times, repeating the above operations. Any decay of voltage does not effect any loss of the stored signal from the pilot.

In case, the signal from the pilot is not recognised, a trial to program from any other pilot should be repeated. Until the signal from the pilot is stored, the Switch is in the programming mode; however, after 5 minutes of inactivity the Switch leaves the programming mode automatically, or it leaves the mode by a manual switching off.

Termination Of The Programming:

- press shortly the button on the Switch, the LED stops to flicker, the Switch remains in a mode as prior to programming, i.e. the assigned button on the pilot is active still, or the Switch is controlled by double pressing of any push-button.

Switching to the double press mode

- switching to the programming mode is effected by pressing quickly 6-times the Switch's button; setting the programming mode is signalled by the light is off and the LED is flickering in a cycle: light is on 1.5s / off 0.5s;
- press and hold down the Switch's button for 3s, when the LED stops to flicker release the button; the Switch resets the stored button and upon double pressing any button on the pilot it commences the remote operation mode.

Diagram of the switch connection to the electric system

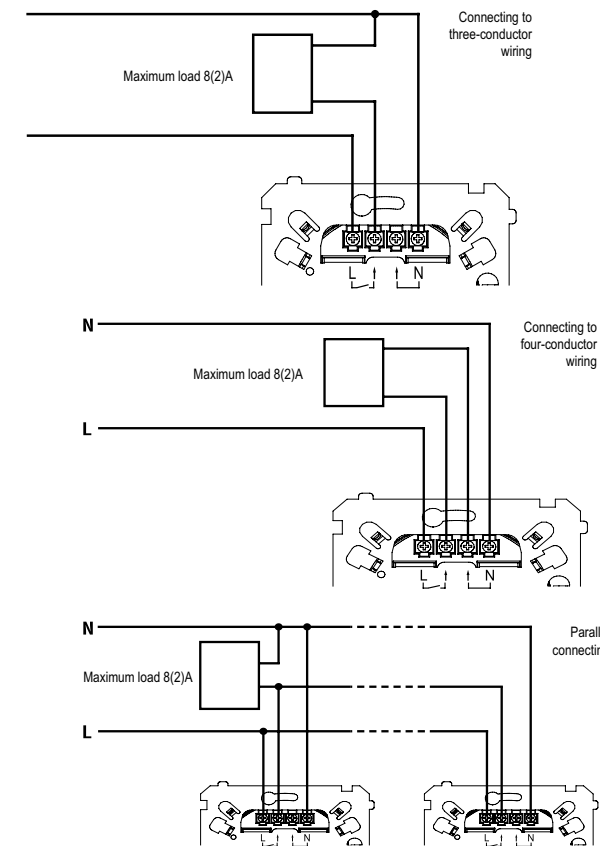

Technical data

Rated voltage	230Vac / 50Hz
Load power, cat. AC1	max 2000W / 8A
Load power, cat. AC3	max 450VA / 2A
Interference level	in accordance with PN-EN-55015
International Protection degree	IP20
Operating mode	continuous
Weight	100g
Range of remote control	6 m if the remote is directed towards the Switch

REMOTE CONTROL SWITCH DWP10T/..

Application

The Remote Control Switch is designed to switch the light on/off in habitable rooms and/or other compartments, as offices, shops, etc. Light switching on/off are effected by pressing the Remote Control Switch push-button, or remotely, using any TV remote controller.

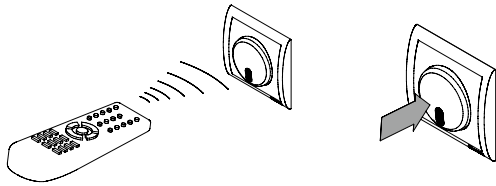

The Remote Control Switch can also be used in any two-way or intermediate type electric system.

Light sources



230V incandescent lamps max 2000 W



230V halogen lamps max 2000 W

12V halogen lamps connected through a core-type toroidal transformer 230V/12V 20 ÷ 500 W

connected through an electronic transformer 230V/12V 20 ÷ 500 W



energy-saving lighting

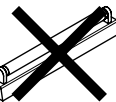

fluorescent lamps



LED lighting



WARNING: The Remote Control Switch is not designed for interoperation with the core-type column transformers, fans and other devices fitted with an electric motor. Failure to observe this warning may cause the Remote Control Switch failure.

Operation

The Remote Control Switch can be directly operated by:

- pressing a push-button of the Remote Control Switch,
- pressing an additional LIGHT push-button, connected to the Remote Control Switch;

or operated remotely by:

- any TV remote controller.

Direct Operation:

A short press of the Remote Control Switch push-button, or the additional switch, effects switching the light on/off.

Operation, using a TV Remote Controller, can be performed in two ways:

1. using any button of the Controller, pressing it twice with an interval not longer than 2 seconds:
 - The first press on the TV controller push-button brings the Remote Control Switch to stand-by, expecting for a next signal from the controller.
 - The Remote Control Switch stand-by is signalled by the LED switch-off lasting ca 2 seconds since the push-button is released, and during that time a second press of the controller push-button should be effected. If the second signal from the controller does not appear, the LED shines again signalling the stand-by mode is over.
 - The second press on the TV controller push-button operates in the same way as a direct operation of the Remote Control Switch push-button.

Upon release of the push-button the LED shines again.

2. using programmed push-button of the TV remote controller, pressing it once. The press of the TV controller push-button operates in the same way as direct operation of the Remote Control Switch pushbutton.

The LED, shining continuously, signals that there are no operation of the TV controller.

Programming of the TV controller push-button

Programming:

1. press quickly the Remote Control Switch push-button 6 times;
2. setting of the programming mode is signalled by the light switched off and the LED flickering in a cycle: light on for 1.5s / off for 0.5s;
3. press and hold down the selected push-button on the TV controller (a push-button that is usually not used to operate TV is the best); upon the signal from the TV controller is stored in, the lamp switch on, and the LED stops to flicker; the Remote Control Switch leaves the programming mode;
4. release the push-button on the TV controller, check switching the light on/off by short pressing the push-button, press another push-button on the TV controller to check whether the Remote Control Switch reacts only to the programmed push-button.

Programming of a push-button can be performed many times, repeating the above operations. Any decay of voltage does not effect a loss of the stored signal from the TV controller.

In case, the signal from the TV controller is not recognised, a trial to program any other TV controller should be repeated. Until the signal from the TV controller is stored, the Remote Control Switch is in the programming mode; however, after 5 minutes of inactivity the Remote Control Switch leaves the programming mode automatically, or it leaves the mode by a manual switching off.

Termination Of The Programming:

1. **No Changes In Programming:** press shortly the push-button on the Remote Control Switch, the LED stops to flicker, the Remote Control Switch remains in a mode as prior to programming, i.e. the stored signal from the TV controller is active still or the Remote Control Switch is controlled upon double pressing of any push-button;
2. **Deleting The Storage:** press and hold down the Remote Control Switch push-button for 3s, when the LED stops to flicker release the push-button, the Remote Control Switch resets the stored push-button, and upon double pressing on any push-button of the TV controller, it enters the remote operation mode.

Short-circuit protection

The Remote Control Switch is furnished with the short-circuit protection system switching off the load circuit (switching off the light) upon exceeding 20A current. When a short-circuit is repaired, the Remote Control Switch may be switched on again. When a bulb 230V is close to be burnt out, current can also achieve a protection limit and that is manifested by automatic switching the light off, preventing the bulb to be burnt out.

When automatic switching the light off is frequent, the bulb should be checked and replaced, if needed.

Overload protection

The Remote Control Switch has an overload protection reducing light brightness after few seconds, according to exceeding the power rating of the Remote Control Switch. In case the power rating is exceeded above 50% the light is completely switched off. Upon the protection system has operated, the Remote Control Switch shifts to the off-state. The LED signals the off cause:
 - single flash: short-circuit,
 - double flash: >50% overload.
 Pressing the Remote Control Switch push-button effects the automatic switch-off mode of the Remote Control Switch is deleted, and the Remote Control Switch is shifted to standard operation.

Diagram of the remote control switch connection to the electric system

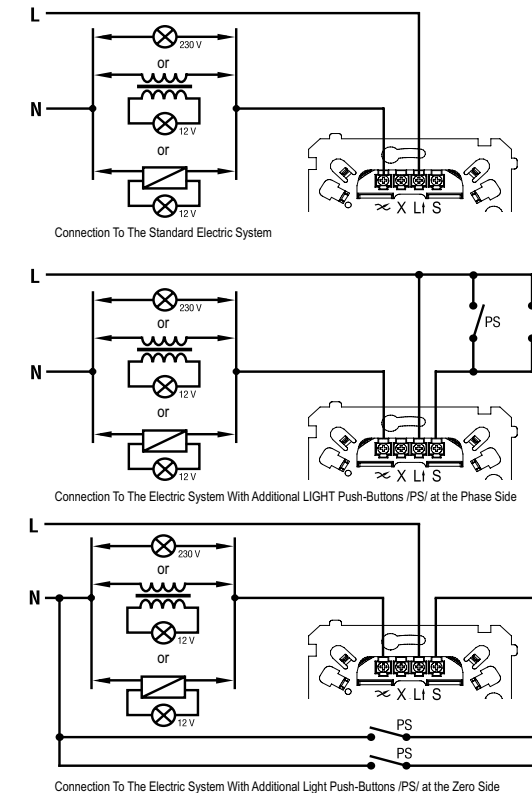

Technical data

Operating Voltage	230V / 50Hz
Load range	5 ÷ 215 W
Type of load	incandescent and 230 V halogen lamps, 12V halogen lamps supplied via core-type or electronic transformers 230 /12 V according to PN-EN-55015
Interference level	IP20
Degree of protection	continuous
Operating mode	smooth - manual (pressing a push-button) - remote (any remote TV controller)
Adjustment mode	110 g
Weight	6 m, aiming the controller at the Remote Control Switch.
Range of remote operation	

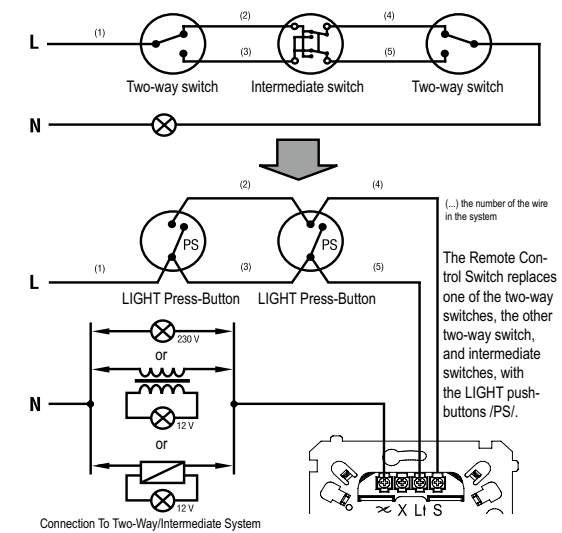

THE RELAY SWITCH WITH A MOTION DETECTOR

**DCR10P.01/...
MCR10P.01/... MCR10P/...
BMC10P/..**



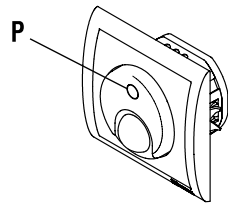

Application

The relay switch with a motion detector is designed for load switching on after any movement in the operating area has been detected, and switching it off after the preset time has been over. It is possible to switch on / off the load permanently with the use of the button /P/.

The relay switch with a motion detector may be used in halls, corridors, staircases, basements, garages, etc.

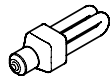
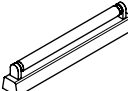

Permissible types of load

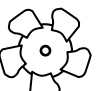
	230Vac incandescent lamps	max 2000W
	230Vac halogen lamps 12Vac halogen lamps connected through a core-type transformer 230/12Vac connected through an electronic transformer 230V/12V	max 2000W max 1000W max 2000W
	energy-saving lamps	max 2000W
	fluorescent lamps without compensation and with the series compensation circuit with the parallel compensation circuit and connected by duo-circuit	max 1000W max 2000W
	LED lamps	max 2000W
	fans	max 450VA

Features of the relay switch with a motion detector

- Automatic (AUTO) load switching on after movement detection for 5 seconds – 21 minutes (smooth adjustment)
- On time elongation after another movement detection
- Enabling the device load switch-on in dependence of external illumination (twilight sensor)
- Permanent load on / off possible
- Twilight sensor preset sensitivity indication

Operation

Relay switch with a motion detector may operate in one of four operating modes: TEST, AUTO, ON, OFF.

TEST mode – the relay switch with a motion detector stays in this mode for one minute after power switching on and after inserting the control unit /1/ again.

The mode is indicated by the LED quick alternating flashing in green and red (0.2/0.2 s).

At that time the relay switch with a motion detector performs the following actions:

- During first 5 seconds it measures illumination versus the reference lighting set with the use of L knob placed at the back of the control unit.
- After 5 seconds the device load will be on.
- After another 5 (50) seconds the device load will be off if external illumination level is greater (less) than the set one.
- After another 50 (5) seconds TEST mode will be terminated and the device will start operating in AUTO mode. It will be indicated by the green LED permanent lighting.

Thanks to TEST mode applying it is possible to set the twilight sensor sensitivity threshold according to description in DEVICE SETTING paragraph.

AUTO mode – This is a basic operating mode of the device. The mode is indicated by the green LED permanent lighting. In this mode, when movement in the operating area is detected, the device load will be on for 5 seconds – 21 minutes in dependence of T knob setting. The knob is placed at the back of the control unit. The time measurement starts from the moment of the movement disappearance. When the device load is on, every subsequent movement detection causes the on time counting from the beginning.

When external illumination level is greater than the twilight sensor sensitivity threshold, preset with the use of L knob, the load will not be on.

ON mode – in this mode the device load is on permanently. The mode is indicated by the LED slow alternating flashing green / red (0.5 / 0.5 s).

OFF mode – in this mode the device load is off permanently. The movement detection function is disabled. The mode is indicated by the red LED permanent lighting.

When the button /P/ is pressed shortly, the relay switch with a motion detector mode switches the operating modes according to the following sequence: AUTO-ON-OFF-AUTO...

Device setting

Twilight Sensor Setting

The procedure should be performed when the room illumination is poor so that it is possible to switch the device.

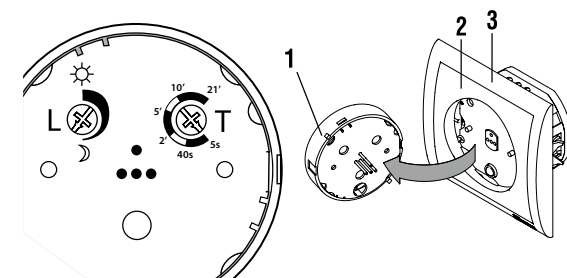

- Remove the control unit /1/ and set L knob in the middle position.
- Insert the control unit /1/ into the sensor body (TEST mode will be entered) and wait for 5 seconds until the device load is on.
- Wait for another 5 seconds. If the device load stays on, remove the control unit and turn L knob towards ☺ symbol in order to decrease the twilight sensor sensitivity threshold. Otherwise, when the load has been off, turn the knob towards ☼ symbol in order to increase the device sensitivity threshold.
- Repeat the procedure again and again until the device load stays on in TEST mode. Every consecutive step rotate the knob by angle less than previously.
- Leave L knob in the set position, wait until TEST mode is terminated (1 minute) and check the sensor in AUTO mode (the device load should be on after movement detection).

After setting L knob in ☼ position the device load will be on every time when movement is detected regardless of external illumination.

The relay switch with a motion detector electrical connection diagram

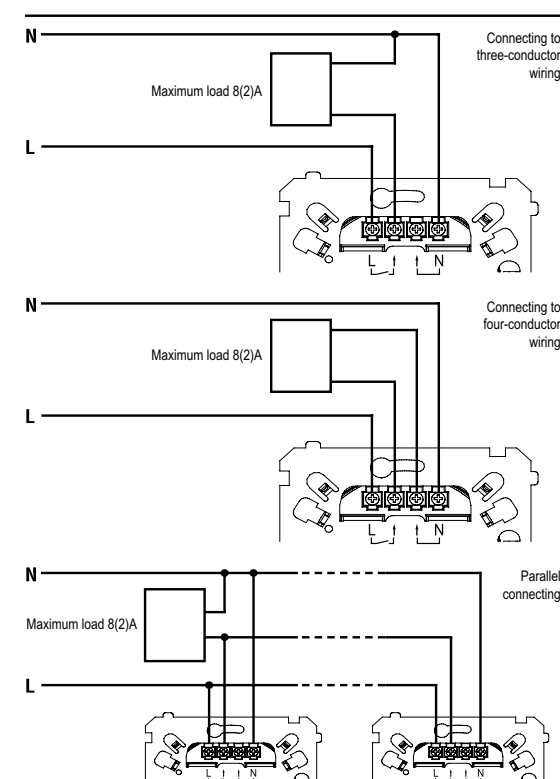

Technical data

Rated voltage	230Vac / 50Hz
Load power, cat. AC1	max 2000W /8A
Load power, cat. AC3	max 450VA /2A
Interference level	in accordance with PN-EN-55015
International Protection degree	IP20
Operating mode	continuous
Operating modes	TEST, AUTO, ON, OFF
Motion detector operating distance	max 7m; 110° horizontally adjusted, 2–500lx
External illumination sensitivity	
Lighting off time after movement disappearance	5s–21min – adjusted
Weight	110g
Mounting height	1.0–2.5m

THE SWITCH WITH A MOTION DETECTOR

DCR10T.01/...
MCR10T.01/..., **MCR10T/11**
BMCR10T.01/..

Application

The switch with a motion detector is designed for the light switching on after any movement in the operating area has been detected, and switching it off after the preset time has been over. It is possible to switch on / off the light permanently with the use of the button /P/.

The switch with a motion detector may be used in halls, corridors, staircases, basements, garages, etc.

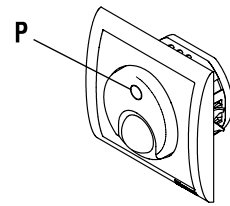

Light sources



230 V incandescent lamps 20÷500 W



230 V halogen lamps 20÷500 W



12 V halogen lamps connected through a core-type toroidal transformer 230V/12V 20÷500 W

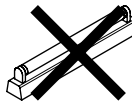

connected through an electronic transformer 230V/12V 20÷500 W

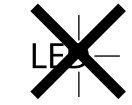

energy-saving lighting

fluorescent lamps

LED lighting



WARNING: The motion detector is not designed for interoperation with the core-type column transformers, fans and other devices fitted with an electric motor. Failure to observe this warning may cause the motion detector failure.

Features of the switch with a motion detector

- Automatic (AUTO) light switching on after movement detection for 5 seconds – 21 minutes (smooth adjustment).
- Light illuminance decreases 5 seconds before off the light.
- On time elongation after another movement detection.
- Enabling the light switch-on in dependence of external illumination (twilight sensor).
- Permanent light on / off possible.
- Twilight sensor preset sensitivity indication.

Operation

The switch with a motion detector may operate in one of four operating modes: TEST, AUTO, ON, OFF.

When the button /P/ is pressed shortly, the relay switch with a motion detector mode switches the operating modes according to the following sequence: AUTO-ON-OFF-AUTO...

TEST mode – the switch with a motion detector stays in this mode for one minute after power switching on and after inserting the control unit /1/ again. The mode is indicated by the LED quick flashing (0.2/0.2 s). At that time the switch with a motion detector performs the following actions:

- During first 5 seconds it measures illumination versus the reference lighting set with the use of L knob placed at the back of the control unit.
- After 5 seconds:
 - full switching on the light connected to the motion detector if outside illuminance is less than the preset one;
 - switching on the light with a minimum power if outside illuminance is greater than the preset one.
- After next 25 seconds: switching off the light connected to the detector.
- After next 30 seconds TEST mode terminates automatically and the detector passes into AUTO mode, in the mode the LED lights continuously.

Thanks to TEST mode applying it is possible to set the twilight sensor sensitivity threshold according to description in DEVICE SETTING paragraph.

AUTO mode – This is a basic operating mode of the device. The mode is indicated by the LED permanent lighting. In this mode, when movement in the operating area is detected, the device load will be on for 5 seconds – 21 minutes in dependence of T knob setting. The knob is placed at the back of the control unit. The time measurement starts from the moment of the movement disappearance. When the device load is on, every subsequent movement detection causes the on time counting from the beginning. When external illumination level is greater than the twilight sensor sensitivity threshold, preset with the use of L knob, the load will not be on. After preset time the control module reduces light illuminance by 50% for 5 seconds to indicate switch-on time termination. If movement is detected again during this period, the control module increases light illuminance to maximum and T time measurement starts from the beginning. If movement is not detected during a period of decreased illuminance, the light is switched off.

Owing to the fact that the light illuminance is decreased towards the end of switch-on period, a person who is in the detector operating range knows that the light will be switched off if the person does not move. If the individual wants to prolong the light switch-on period the person should simply move.

ON mode – In this mode the device light is on permanently. The mode is indicated by the LED slow flashing (0.5 / 0.5 s). In this case it is possible to adjust desired illuminance level. In order to adjust the level it is necessary to press and hold the button. Illuminance level changes from minimum to maximum. It is possible to adjust the level, regardless of an actual operating mode, by pressing and holding the button /1/. In this case there is no need to changeover into ON mode. After illuminance level adjustment the detector stays in ON mode. Preset illuminance level is stored in memory until module power supply is switched off. After TEST mode termination illuminance level is set for maximum.

OFF mode – In this mode the light is switched off continuously and movement detection is disabled. The LED is switched off.

In AUTO mode illuminance level is set for maximum.

Device setting

Twilight Sensor Setting

The procedure should be performed when the room illumination is poor so that it is possible to switch the device.

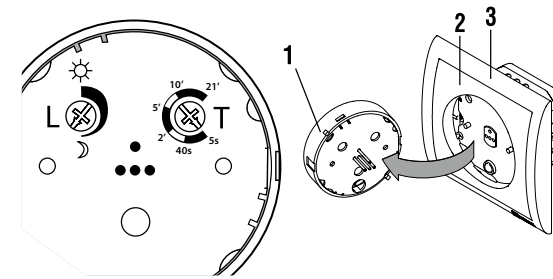

- Remove the control unit /1/ and set L knob in the middle position,
- Insert the control unit /1/ into the sensor body (TEST mode will be entered) and wait for 5 seconds until the light is on,
- In case the lamp is set on a full intensity of the light, then if the control unit is removed the knob L should be turned toward ⤵ lowering the actuation threshold of the twilight sensor; on the contrary, in case the lamp is set on a minimal intensity of the light, turn the knob L toward ⤴ raising the actuation threshold. Repeat the above two instructions few times turning the knob L by a smaller and smaller angle, till finding the position where the lamp in the TEST mode is turned on the full intensity of the light,
- Leave L knob in the set position, wait until TEST mode is terminated (1 minute) and check the sensor in AUTO mode (the light should be on after movement detection).

After setting L knob in ⤴ position the light will be on every time when movement is detected regardless of external illumination.

The switch with a motion detector electrical connection diagram

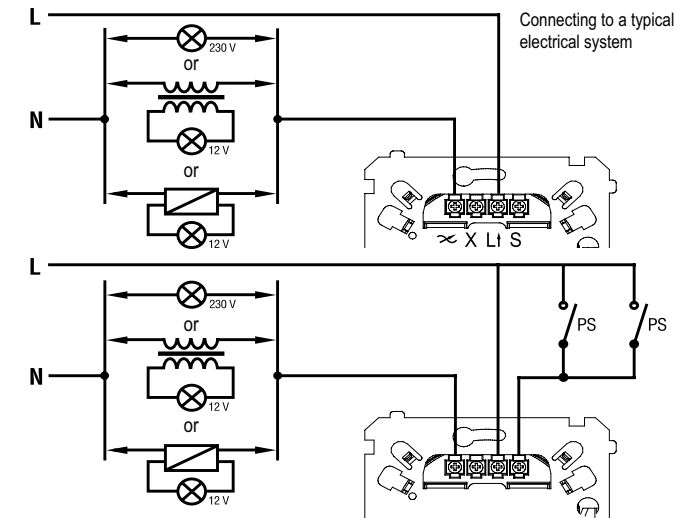

Short circuit protection

The switch with a motion detector is fitted with the short circuit protection that switches the load (lighting) OFF when the load current exceeds 20 A. After the short circuit cause removal it is possible to switch the AUTO mode again.

In case of burnout of 230 V light bulb the load current may reach the limit value what will cause the the lighting switching OFF and prevent the bulb from complete burnout. **When the automatic switching OFF repeats over and over again it is necessary to check the bulb state and replace it if needed.**

Overload protection

The switch with a motion detector is furnished with the overload protection appliance, that when the rated load power is exceeded by 30% the intensity of the lighting is gradually lowered till a final switch off.

Upon the protection appliance is actuated, the switch with a motion detector passes to the OFF mode (lighting is off).

The LED indicates the cause of the cut-off:

- a single flash means a short-circuit appearance,
- a double flash means an overload appearance.

Pressing of the /P/ push-button erases signalling of the automatic switch-off, and switches the motion sensor to the AUTO mode.

THE RELAY SWITCH WITH A MOTION DETECTOR

DCR11P.01/..., BMR11P.01/..



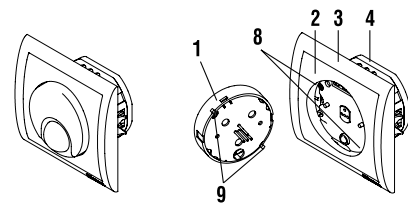

Application

The relay switch with a motion detector is designed for load switching on after any movement in the operating area has been detected, and switching it off after the preset time has been over. The switch has additional hitches /9/ set on the control unit /1/ and screws /8/ fastening the cover /2/ with its frame /3/ to the operating set /4/ protecting the set against dismantling by unauthorized persons.

The switch is designed to be installed in public buildings, as hotels, commercial buildings, general-purpose rooms in dwelling houses, etc.

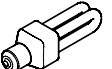
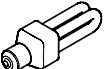
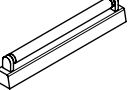
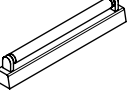

Permissible types of load

	230Vac incandescent lamps	max 2000 W
	230Vac halogen lamps	max 2000 W
	12Vac halogen lamps connected through a core-type transformer 230/12Vac	max 1000 W
	connected through an electronic transformer 230/12Vac	max 2000 W
	energy-saving lamps	max 2000 W
	fluorescent lamps without compensation and with the series compensation circuit	max 1000 W
	with the parallel compensation circuit and connected by duo-circuit	max 2000 W
	LED lamps	max 2000 W
	fans	max 450 VA

Features of the relay switch with a motion detector

- Automatic (AUTO) load switching on after movement detection for 5 seconds – 21 minutes (smooth adjustment)
- On time elongation after another movement detection
- Enabling the device load switch-on in dependence of external illumination (twilight sensor)
- Twilight sensor preset sensitivity indication
- Hitches /9/ protecting from control unit /1/ removal.

Operation

Relay switch with a motion detector may operate in one of two operating modes: TEST, AUTO.

TEST mode – the relay switch with a motion detector stays in this mode for one minute after power switching on and after inserting the control unit /1/ again.

The mode is indicated by the LED quick alternating flashing in green and red (0.2/0.2 s).

At that time the relay switch with a motion detector performs the following actions:

- During first 5 seconds it measures illumination versus the reference lighting set with the use of L knob placed at the back of the control unit.
- After 5 seconds the device load will be on.
- After another 5 (50) seconds the device load will be off if external illumination level is greater (less) than the set one.
- After another 50 (5) seconds TEST mode will be terminated and the device will start operating in AUTO mode. It will be indicated by the green LED permanent lighting.

Thanks to TEST mode applying it is possible to set the twilight sensor sensitivity threshold according to description in DEVICE SETTING paragraph.

AUTO mode – This is a basic operating mode of the device. The mode is indicated by the green LED permanent lighting. In this mode, when movement in the operating area is detected, the device load will be on for 5 seconds - 21 minutes in dependence of T knob setting. The knob is placed at the back of the control unit. The time measurement starts from the moment of the movement disappearance. When the device load is on, every subsequent movement detection causes the on time counting from the beginning. When external illumination level is greater than the twilight sensor sensitivity threshold, preset with the use of L knob, the load will not be on.

Device setting

Twilight Sensor Setting

The procedure should be performed when the room illumination is poor so that it is possible to switch the device.

It is advised to apply the settings without the cover /2/ in order to avoid multi-snapping of the control unit on the hitches /9/.

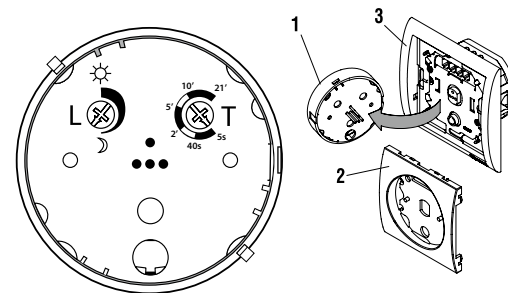

- Remove the control unit /1/ and set L knob in the middle position.
- Insert the control unit /1/ into the sensor body (TEST mode will be entered) and wait for 5 seconds until the device load is on.
- Wait for another 5 seconds. If the device load stays on, remove the control unit and turn L knob towards \gg symbol in order to decrease the twilight sensor sensitivity threshold. Otherwise, when the load has been off, turn the knob towards \odot symbol in order to increase the device sensitivity threshold.

- Repeat the procedure again and again until the device load stays on in TEST mode. Every consecutive step rotate the knob by angle less than previously. Leave L knob in the set position, wait until TEST mode is terminated
- (1 minute) and check the sensor in AUTO mode (the device load should be on after movement detection).

After setting L knob in \odot position the device load will be on every time when movement is detected regardless of external illumination.

When the setting up is completed, put the cover /2/ on and fasten with screws /8/, then insert the control unit /1/ till it is snapped in hitches /9/. The setting up anew is possible when the control unit is removed, as shown in the drawing beneath. In case the motion sensor is not exposed to any unauthorized interference, the hitches /9/ may be cut off and the cover not fastened with screws /8/.

The relay switch with a motion detector electrical connection diagram

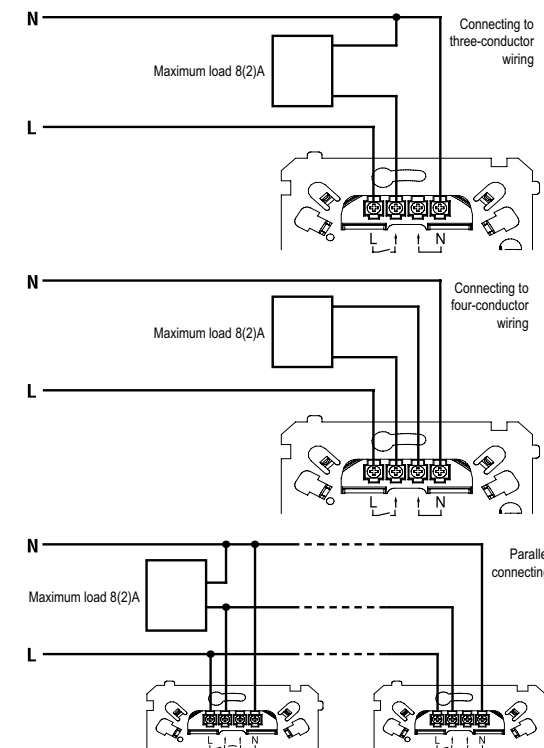
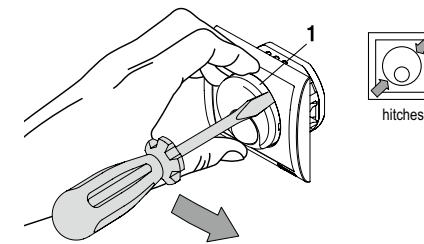

Technical data

Rated voltage	230Vac / 50Hz
Load power, cat. AC1	max 2000 W / 8 A
Load power, cat. AC3	max 450 VA / 2 A
Interference level	in accordance with PN-EN-55015
International Protection degree	IP20
Operating mode	continuous
Operating modes	TEST, AUTO
Motion detector operating distance	max 7 m; 110° horizontally
External Illumination sensitivity	adjusted 2 – 500 lx
Lighting off time after movement disappearance	5 s – 21 min – adjusted
Weight	110g
Mounting height	1.0-2.5 m

THE SWITCH WITH A MOTION DETECTOR

DCR11T.01/... BMC R11T.01/..

NOTE:

Read this Instruction Manual carefully!
Disconnect your home electric network with the use of appropriate fuses. Only qualified technicians are allowed to connect the device to an electric network.

Application

The relay switch with a motion detector is designed for load switching on after any movement in the operating area has been detected, and switching it off after the preset time has been over. The switch has additional hinges /9/ set on the control unit /1/ and screws /8/ fastening the cover /2/ with its frame /3/ to the operating set /4/ protecting the set against dismantling by unauthorized persons.

The switch is designed to be installed in public buildings, as hotels, commercial buildings, general-purpose rooms in dwelling houses, etc.

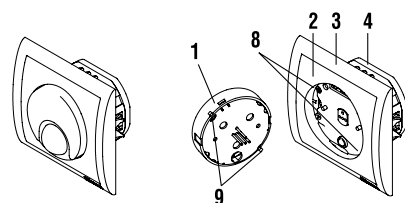

Light sources

	230 V incandescent lamps	20 ÷ 500 W
	230 V halogen lamps 12 V halogen lamps connected through a toroidal core-type transformer 230/12Vac connected through an electronic transformer 230/12Vac	20 ÷ 500 W 20 ÷ 500 W
	Energy-save lighting	
	Fluorescent lamps	
	LED lamps	



WARNING: The motion detector is not designed for interoperation with the core-type column transformers, fans and other devices fitted with an electric motor. Failure to observe this warning may cause the motion detector failure.

Features of the relay switch with a motion detector

- Automatic (AUTO) load switching on after movement detection for 5 seconds – 21 minutes (smooth adjustment)
- Light illuminance decreases 5 seconds before off the light
- On time elongation after another movement detection
- Enabling the device load switch-on in dependence of external illumination (twilight sensor)
- Twilight sensor preset sensitivity indication
- Hitches /9/ protecting from control unit /1/ removal

Operation

The switch with a motion detector may operate in one of two operating modes: TEST, AUTO

TEST mode – the switch with a motion detector stays in this mode for one minute after power switching on and after inserting the control unit /1/ again.

The mode is indicated by the LED quick flashing (0.2/0.2 s).

At that time the switch with a motion detector performs the following actions:

- During first 5 seconds it measures illumination versus the reference lighting set with the use of L knob placed at the back of the control unit.
- After 5 seconds:
 - full switching on the light connected to the motion detector if outside illuminance is less than the preset one;
 - switching on the light with a minimum power if outside illuminance is greater than the preset one.
- After next 25 seconds: switching off the light connected to the detector.
- After next 30 seconds TEST mode terminates automatically and the detector passes into AUTO mode, in the mode the LED lights continuously.

Thanks to TEST mode applying it is possible to set the twilight sensor sensitivity threshold according to description in DEVICE SETTING paragraph.

AUTO mode – This is a basic operating mode of the device. The mode is indicated by the LED permanent lighting. In this mode, when movement in the operating area is detected, the device load will be on for 5 seconds – 21 minutes in dependence of T knob setting. The knob is placed at the back of the control unit. The time measurement starts from the moment of the movement disappearance. When the device load is on, every subsequent movement detection causes the on time counting from the beginning. When external illumination level is greater than the twilight sensor sensitivity threshold, preset with the use of L knob, the load will not be on. After preset time the control module reduces light illuminance by 50% for 5 seconds to indicate switch-on time termination. If movement is detected again during this period, the control module increases light illuminance to maximum and T time measurement starts from the beginning. If movement is not detected during a period of decreased illuminance, the light is switched off.

Owing to the fact that the light illuminance is decreased towards the end of switch-on period, a person who is in the detector operating range knows that the light will be switched off if the person does not move. If the individual wants to prolong the light switch-on period the person should simply move.

Device setting

Twilight Sensor Setting

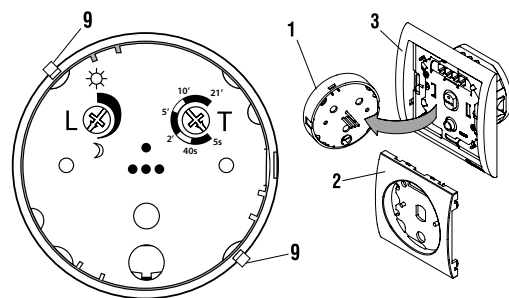

The procedure should be performed when the room illumination is poor so that it is possible to switch the device.
It is advised to apply the settings without the cover /2/ in order to avoid multi-snapping of the control unit on the hinges /9/.

- Remove the control unit /1/ and set L knob in the middle position.
- Insert the control unit /1/ into the sensor body (TEST mode will be entered) and wait for 5 seconds until the device load is on.
- Wait for another 5 seconds. If the device load stays on, remove the control unit and turn L knob towards \curvearrowright symbol in order to decrease the twilight sensor sensitivity threshold. Otherwise, when the load has been off, turn the knob towards \curvearrowleft symbol in order to increase the device sensitivity threshold.
- Repeat the procedure again and again until the device load stays on in TEST mode.
- Every consecutive step rotate the knob by angle less than previously. Leave L knob in the set position, wait until TEST mode is terminated (1 minute) and check the sensor in AUTO mode (the device load should be on after movement detection).

After setting L knob in \curvearrowleft position the device load will be on every time when movement is detected regardless of external illumination.

When the setting up is completed, put the cover /2/ on and fasten with screws /8/, then insert the control unit /1/ till it is snapped in hinges /9/. The setting up anew is possible when the control unit is removed, as shown in the drawing beneath. In case the motion sensor is not exposed to any unauthorized interference, the hinges /9/ may be cut off and the cover not fastened with screws /8/.

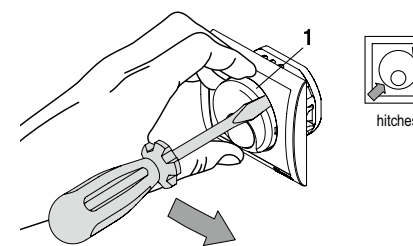

The switch with a motion detector electrical connection diagram

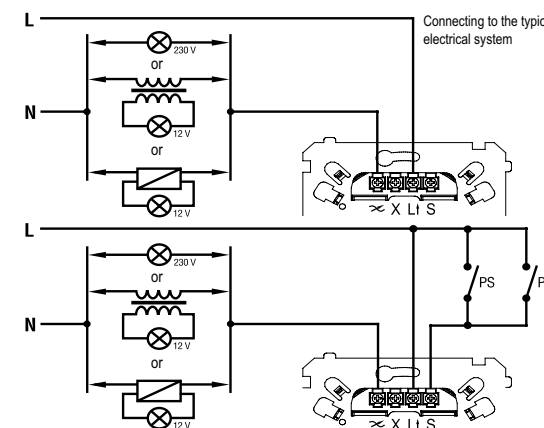

Short circuit protection

The switch with a motion detector is fitted with the short circuit protection that switches the load (lighting) OFF when the load current exceeds 20 A. After the short circuit cause removal it is possible to switch the AUTO mode again. In case of burnout of 230 V light bulb the load current may reach the limit value what will cause the the lighting switching OFF and prevent the bulb from complete burnout. **When the automatic switching OFF repeats over and over again it is necessary to check the bulb state and replace it if needed.**

Overload protection

The switch with a motion detector is furnished with the overload protection appliance, that when the rated load power is exceeded by 30% the intensity of the lighting is gradually lowered till a final switch off.

Upon the protection appliance is actuated, the switch with a motion detector passes to the OFF mode (lighting is off). The LED indicates the cause of the cut-off:

- a single flash means a short-circuit appearance,
- a double flash means an overload appearance.

Switching OFF/ON the fuses of house installation erases signalling of the automatic switch-off, and switches the motion sensor to the AUTO mode.

Technical data

Rated voltage	230Vac / 50Hz
Load range	20 ÷ 500W
Interference level	in accordance with PN-EN-55015
International Protection degree	IP20
Operating mode	continuous
Operating modes	TEST, AUTO
Motion detector operating distance	max 7m; 110° horizontally
External illumination sensitivity	adjusted, 2 – 500lx
Lighting off time after movement disappearance	5 s – 21 min – adjusted
Weight	110g
Mounting height	1.0 – 2.5m

RELAY SWITCH WITH TIMER

DWC10P.01/..
MWC10P.01/..,
MWC10P/..





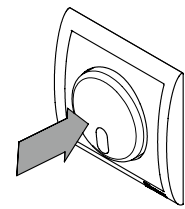

Application

The relay timer is designed for the load switching on and automatic switching off after the preset time has been over. It is possible to switch on / off the load before the preset time terminates.

The relay timer may be used in halls, staircases, basements, garages, doctor's surgeries, hospitals (bactericidal lamps control), etc.



Permissible types of load

	230Vac incandescent lamps	max 2000W
	230Vac halogen lamps 12Vac halogen lamps connected through a core-type transformer 230/12Vac connected through an electronic transformer 230V/12V	max 2000W max 1000W max 2000W
	energy-saving lamps	max 2000W
	fluorescent lamps without compensation and with the series compensation circuit with the parallel compensation circuit and connected by duo-circuit	max 1000W max 2000W
	LED lamps	max 2000W
	fans	max 450VA

The relay timer features

- Load switch-on time 0.5–99 minutes (discrete settings, every 1 minute)
- Permanent load on possible (by means of pressing an appropriate key button for 3 s)
- load switching off possible at any moment by means of pressing an appropriate key button
- Protection against the button locking

Device functioning

Relay timer enables load switching on for the time set within the range of 0.5–99 minutes (TIME mode) or permanently (CONTINUOUS mode).

- When the key button /1/ is pressed shortly, the load will be on for the time set with the use of the knobs placed at the back of the key button (TIME mode). The load will be off automatically after the preset time is terminated or at any moment after the key button has been pressed before the on-time terminating. The OFF state is indicated by the red LED lighting, and the ON state – green LED.
 - When the key button is pressed again (for more than 3 seconds) the device load will be on permanently (CONTINUOUS mode). The state is indicated by the LED flashing alternately in green and red (0.5 / 0.5 s). The next key button pressing (shortly) will cause the device load to be off.
- In CONTINUOUS mode the relay timer operates as a normal switch manually controlled.

It is possible to select CONTINUOUS mode permanently by setting D knob in ∞ position. In this case, in order to switch on / off the device load it is necessary to press the key button shortly.

Additionally, relay timer is protected against permanent pressing the key button, e.g. locking by an object. In such a case the device load will be off after 10 seconds. Another load switching on is possible after interlocking removal.

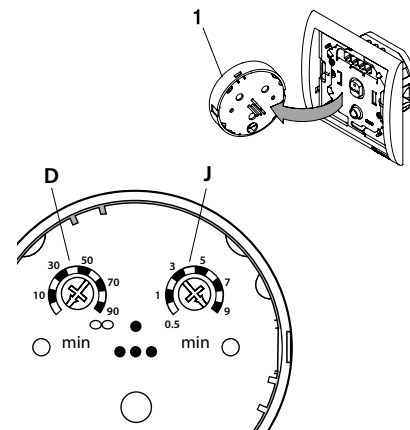

Device setting

- Remove the key button /1/ and set the requested ON-time, in minutes, by means of J (units) and D (tens) knobs. The knob settings sum up.
- insert the key button /1/ back. After you release the key button the LEDs will start flashing in order to show the selected ON-time according to the table below:

Number of the green LED flashes	D setting	Number of the red LED flashes	J setting
0	0 min	0	0.5 min
1	10 min	1	1.0 min
2	20 min	2	2.0 min
•	•	•	•
•	•	•	•
9	90 min	9	9.0 min
10	∞ – CONTINUOUS mode	0	any

Relay timer electrical connection diagram

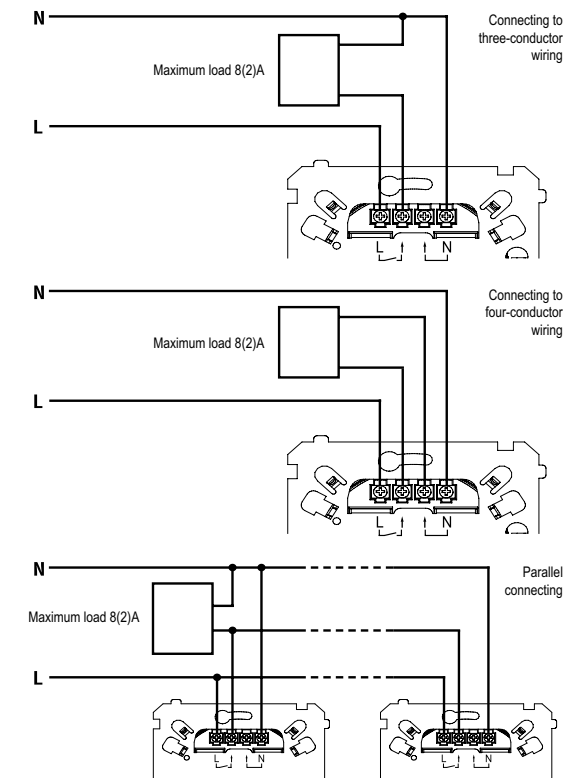

Technical data

Rated voltage	230Vac / 50Hz
Load power, cat. AC1	max 2000W / 8A
Load power, cat. AC3	max 450W / 2A
Interference level	in accordance with PN-EN-55015
International Protection degree	IP20
Operating mode	continuous
Operating modes	TIME, CONTINUOUS
Switch-on time	0.5–99 minutes (discrete settings, every 1 minute)
Weight	100g
Mounting height	1.0–2.5m

TIMER SWITCH DWC10T.01/.. MWC10T.01/.. MWC10T/..

Application

The Time Switch is designed to switch the lighting system on and/or to switch the lighting system automatically off upon the pre-set time elapses. Also, the lighting system can be switched any time on, or off prior the preset time elapses. The Time Switch can be applied indoor, in compartments as anterooms, staircases, cellars, garages, etc.

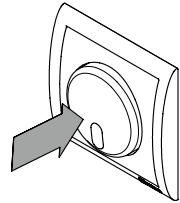

Light sources



230V incandescent lamps 20 ÷ 500 W



230V halogen lamps 20 ÷ 500 W



12V halogen lamps connected through a core-type toroidal transformer 230V/12V or connected through an electronic transformer 230W/12V 20 ÷ 500 W

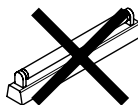

energy-saving lighting



fluorescent lamps



LED lighting



WARNING: The dimmer is not designed for inter-operation with the core-type column transformers, fans and other devices fitted with an electric motor. Failure to observe this warning may cause the dimmer failure.

Operation

The Time Switch has a capacity to switch the light on for a pre-set time of 15s ÷ 10min, or for an extended 30min time.

- Short pressing of the button IM effects the light is switched on for a time pre-set with a knob placed a the button back.
- Longer (more than 1 s) pressing of the button effects the light is switched on for the extended 30min time signaled by a LED flicker.

Upon the pre-set time elapses, the Time Switch lowers the light brightness for a half, signaling thereby termination of the pre-set time. Such a condition is maintained for 15s when a short lighting time is concerned, and for 15s for a long lighting time, and then the light is off.

Pressing the button, prior the pre-set time elapses, stops the timing and switches the light off. Pressing the button during the termination signaling period switches the light on again, for a pre-set time.

Additionally, the Time Switch is equipped with a protection against effects of uncontrolled permanent pressing of the button, e.g. the button is blocked with any object. In such a situation, upon the pre-set time and the following termination time elapse, the light is switched off. Switching the light on again is possible only when the blocking is removed and then the button is pressed again.

Setting up

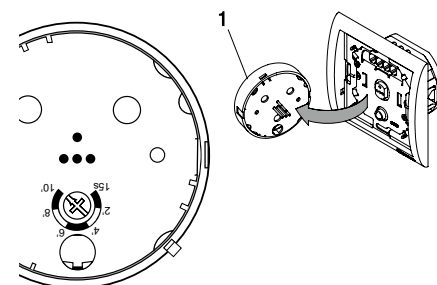

- Remove the button /1/ and, using a knob, set the required lighting time up, following the description at the back of the button.
- Insert the button /1/ back, pressing shortly the button switch the light on, and check whether the time is set up as required.
- If the time is set up inconsistently with requirements, remove the button again and set up as required.

Diagram of the time switch connection to the electric system

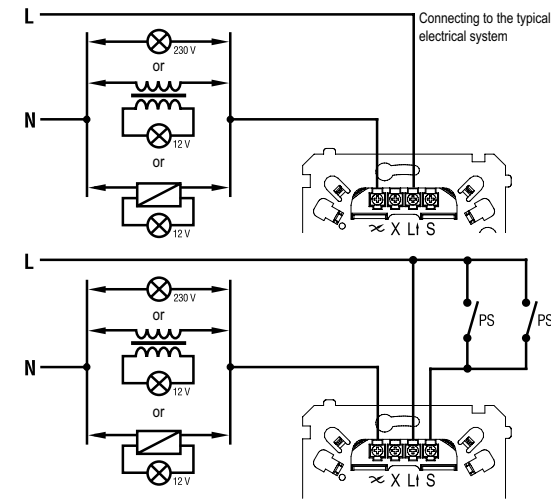

Short-circuit protection

The Time Switch is equipped with the short-circuit protection system switching off the circuit (switching off the light) upon the 20A current is exceeded. When a short-circuit is repaired, the Time Switch may be switched on again.

When a bulb 230V is close to be burnt out, current can also achieve a protection limit and that is manifested by automatic switching the light off, preventing the bulb to be burnt out.

When automatic switching the light off is frequent, the bulb should be checked and replaced, if needed.

Overload protection

In case the power rating is exceeded above 50% the light is switched off completely.

Upon the protection system has operated, the Time Switch is shifted to the off-mode.

The LED signals the off cause:

- single flash: short-circuit,
- double flash: >50% overload.

Pressing the Time Switch button effects the automatic switch-off mode of the Time Switch is deleted, and the Time Switch is shifted to standard operation.

Technical data

Operating Voltage	230V / 50Hz
Power	20 ÷ 500 W
Load	230V halogen & incandescent lamps, 12V halogen lamps, through a core-type, toroidal, or electronic transformer 230V /12V according to PN-EN-55015
Level of interference	IP20
Protection degree	continuous
Mode of operation	15s up to 10min (smooth adjustment)
Time of operation	30min
Extended time of operation	110 g
Weight	

TEMPERATURE REGULATOR

..RT10w/.. with inner (air) sensor
..RT10z/.. for outer (floor) sensor NTC-03
 (sensor included)

Application

The temperature regulator is designed to control underfloor heating systems, electric heaters, etc. in a manner assuring maintenance of constant temperature.

Total power of the connected load may not exceed 3600W for voltage 230V. Load of higher power shall be connected through an additional contactor.

The ..RT10w/.. regulator with an inner sensor enables maintenance of constant air temperature in a room, and the ..RT10z/.. regulator with connected an outer NTC-03 type sensor placed in the floor enables maintenance of constant temperature of underfloor heating. An external sensor connecting cable may be extended up to 50m. The regulator can be mounted by use of screws in flush-mounted \varnothing 60 mm terminal boxes and surface boxes and in multiple-box sets CLASSIC (MRT10../..) or Simon54 Premium (DRT10../..).

Design and operation

The regulator has a 16A double-pole switch (W) that guarantees complete disconnection of the load circuit from the network and a 16A output relay (P). It also has a protection system to switch off the load circuit in case of short-circuit or sensor circuit failure. A red LED signals switching on of the load circuit. The regulator switches the load circuit ON/OFF in cycles to assure maintenance of constant temperature set by an adjustment knob.

Terminals enable connection of single conductors with sections of 4 mm² or two conductors of sections 2.5 mm². A terminal for connection of a protection conductor enables maintenance of protection circuit continuity. There are grooves around 1/3 of a knob axis and a tongue in a knob hole that fits into them. This enables setting of the knob adequate to the user's needs. In order to adjust the setting, the knob must be taken out, turned in a suitable direction and pushed in again.

The following temperatures correspond with the individual points of the scale: 1 - 5°C; 2 - 14°C; 3 - 22.5°C; 4 - 31 °C; 5 - 40°C.

Installation recommendations

The regulator should be installed on a wall, 1.0-1.5m above the floor level, in a heated room in a place assuring free air circulation, oriented in such a way that the knob is placed on the right (see the figure 'Method of Installation'). It should not be exposed to direct action of other sources of heat (e.g., the sun), to draughts (close to windows, doors, etc.) or water.

Attention should be paid to correct connection of power supply, i.e. a phase conductor to L terminal and a neutral conductor to N terminal.

Technical data

Operating voltage	230 V \pm 10% / 50 Hz
Load current	16 A – cat. AC1 (resistance load) 2 A – cat. AC3 (inductive load)
Type of load	resistance – cable or heating mat, electric heaters inductive – fan, blown air heating
Type of disconnecting	16A double-pole switch
Temperature regulation range	5–40°C
Temperature hysteresis	\pm 0,3°C
Type of operation	automatic
Method of regulation	ON-OFF
Protection	against short-circuit or sensor circuit failure
Type of sensor	inner (air) – in regulator types ..RT10w/.. outer (floor) NTC-03 – for regulator types ..RT10z/.. rotary potentiometer
Temperature setting	95 g
Weight	1,0–1,5 m.
Height of installation	IP20
Protection class	conforming to PN EN 50014
Level of interference	PN-EN 60730-1, PN-EN 60730-2-9
Referenced standards	

Diagram of regulator connection to the electrical system

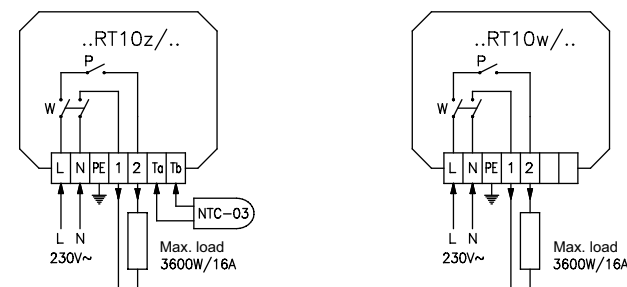

R-TV FINAL ANTENNA SOCKET, SEPARATED

type AAK/...,
MAK2/...,
AK2M

Purpose

The antenna socket is applied in personal and community networks or cable TV systems and is used for the connection of devices such as a television set, VCR or a radio receiver to these networks.

Application

The inputs of the socket are adapted for the connection of a concentric cable with a 75 Ω impedance, providing signal from receiving antennas. The outputs are made in line with the IEC standard allowing for the connection of a radio receiver or a TV-set. Due to a suitable structure of the outputs, the signals of the following frequency ranges are transmitted:

- TV output: 5 ÷ 70 MHz and 120 ÷ 862 MHz
- R output: 88 ÷ 108 MHz

Coupling attenuation of TV and R outputs: 1. -1.5 dB

The final antenna socket is used in community networks with star topology and in personal single-outlet systems, where the amplifier is based by the antenna while the power supply is located by the TV receiver before the antenna socket. A special structure allows for the power supply of the amplifier based by the antenna by means of an antenna cable.

